



KMF 062 01

NEW

Allied Motion



KinetiMax HPD Brushless DC Outer-Rotor Motors High Power Density, Frameless Stator-Rotor Sets

62 to 125 mm diameter, 0.16 to 6.30 Nm continuous torque, up to 1100 Watts output

Motion Solutions
that Change the Game



KMF 062 01

KinetiMax HPD Brushless DC Outer-Rotor Motors High Power Density, Frameless Stator-Rotor Sets

62 to 125 mm diameter, 0.16 to 6.30 Nm continuous torque, up to 1188 Watts output



The KinetiMax HPD range of outer-rotor brushless DC motors comes in frameless stator-rotor part sets. Available in six frame sizes and three stack-heights each, the HPD series enables you to select an optimum configuration with an exact performance fit for your application.

These compact kit motors offer an ideal solution especially where total motor length is crucial in space-constrained applications.

Their large stator ID (Inner Diameter) makes integration of larger ball-bearings possible, and the large clear aperture ID permits cabling to pass through the motor.

The HPD's excellent high torque-to-weight ratio is essential in applications where weight is critical. And with an efficiency ranging from 81% to 91% in a wide speed-torque range, the KinetiMax HPD frameless motors are ideal for battery-fed applications, where they help maximize the running time per battery charge.

Their low cogging torque combined with high peak torque improves motor behavior in servo applications.

Features & Benefits

- Winding selection for other Voltages
- Rated torque 0.16 to 6.30 Nm
- High torque-to-weight ratio
- Excellent efficiency from 81% up to 91% over a wide range around the nominal working point

Options & Accessories

- Hall commutation sensor board
- Temperature sensor mounted on stator

Typical Applications

- Automated Guided Vehicles (AGV)
- Robotics (arms, joints)
- Handheld hydraulic power tools
- Material handling systems
- Medical equipment
- Rotary actuators
- Gimbals



KMF 062 01

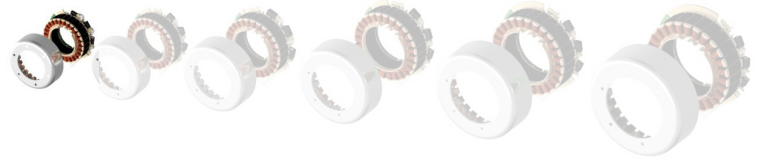

Specifications

Winding Identification ³		C	D	E	F	G	H	J	K
Nominal Supply Voltage DC Link	Volt	12	15	18	24	36	48	60	72
Rated Output Power ¹	Watt	92	92	80	85	93	93	89	80
Rated Speed	rpm	5546	5554	4779	5119	5558	5576	5341	4793
Rated Torque ¹	Nm	0.16							
Rated Line Current ^{1,4}	Arms	6.6	5.3	3.8	3.1	2.2	1.7	1.3	1.0
Max. Efficiency	%	82							
No Load Speed RPM (@ nominal voltage)	rpm	5868	5868	5082	5420	5868	5868	5646	5082
BEMF Constant Ke	V/krpm	2.0	2.6	3.5	4.4	6.1	8.2	10.6	14.2
Motor Speed Constant Kv (=1/Ke)	rpm/V	489.0	391.2	282.3	225.8	163.0	122.2	94.1	70.6
Continuous Stall Torque ¹	Nm	0.20							
Continuous Stall Line Current (rms) ¹	Arms	8.4	6.7	4.8	3.9	2.8	2.1	1.6	1.2
Peak Torque	Nm	0.64							
Max. Demagnetization Line Current	A	70	56	41	33	23	18	14	10
Torque/rms Line Current Kt ⁴	Nm/Arms	0.024	0.030	0.041	0.052	0.072	0.096	0.124	0.166
Resistance (terminal-to-terminal)	mOhm	81	123	228	355	701	1172	2068	3480
Inductance (terminal-to-terminal)	μH	26	40	77	120	231	410	692	1230
Back EMF (@3000 RPM terminal-to-terminal)	Vrms	1.4	1.8	2.5	3.1	4.3	5.8	7.5	10.0
Thermal Resistance (stator/rotor to ambient) ¹	°C/W	4.43							
Thermal Resistance Winding-Housing	°C/W	3.88							
Max. Winding Temperature	°C	160							
Number of Pole Pairs		15							
Weight	kg	0.15							
Rotor Inertia - Large I.D.	kgm ² * E-6	44							
Rotor Inertia - Small I.D.	kgm ² * E-6	46							
Mechanical Time Constant	ms	6.2							
Electrical Time Constant	ms	0.3							
Motor Constant Km	Nm/sqrt(W)	0.071							
Cogging Torque (typical, peak to peak)	Nm	0.004							
Drag Torque	Nm	0.004							
Viscous Damping	Nm/rpm	3.1E-06							
Thermal Time Constant of Winding only	s	18							
Adiabatic Heating of Winding at Peak Torque	K/s	13							
Rotor Inner Diameter [V] ²	mm	38							
Rotor Inner Diameter [W] ²	mm	16							
Rotor Outer Diameter [Z] ²	mm	61.9							
Stator Inner Diameter [Y] ²	mm	32.0							
Total Height [X] ²	mm	23.1							
Motor lead wire AWG size		16	16	16	16	20	20	20	20

(1) Assuming the stator-rotor set is mounted on a bracket with an aluminium flange diameter 1.5 times rotor diameter.

(2) See the dimensions in the drawing on the next page.

(3) Windings C, D, G and H are delta connected, windings E, F, J and K are wye connected.

(4) Line currents are the AC currents running into the three terminals of the stator.

Performance

T-n and T-I curves

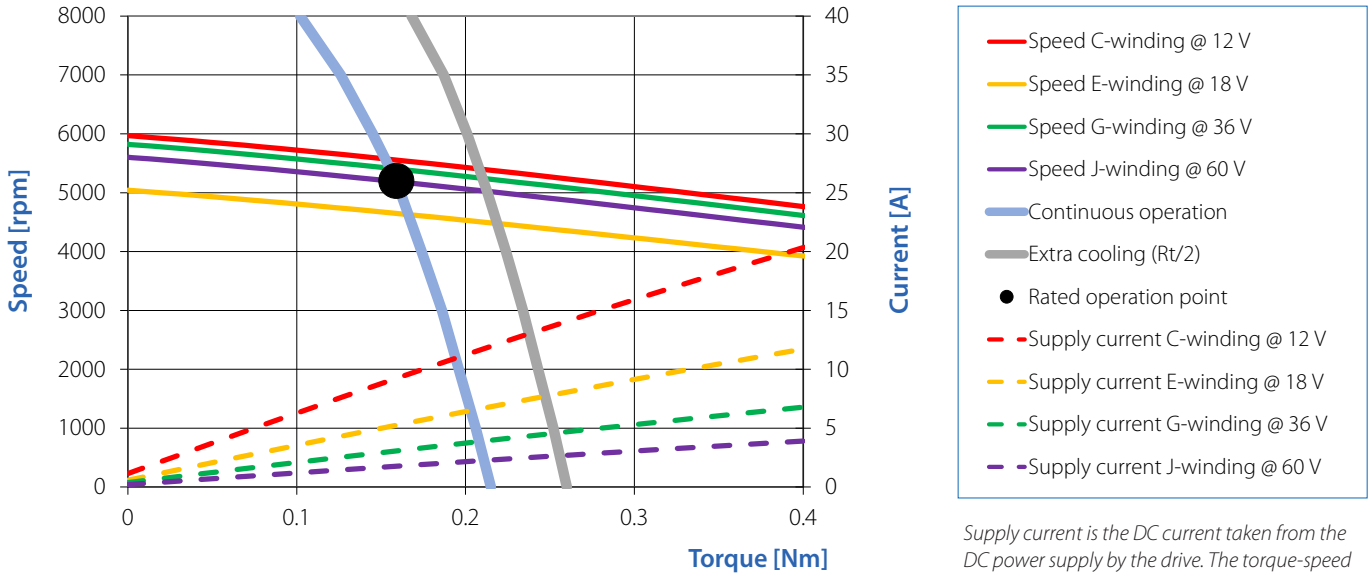

Supply current is the DC current taken from the DC power supply by the drive. The torque-speed curves and torque-current curves are made assuming a FOC drive is used.

T-Efficiency

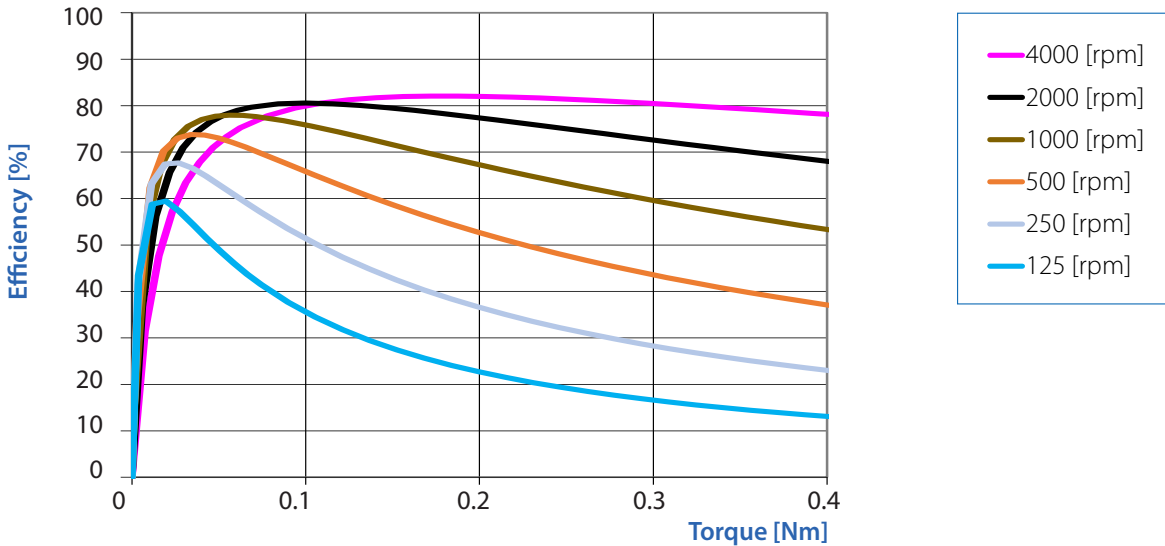

Outline Dimensions

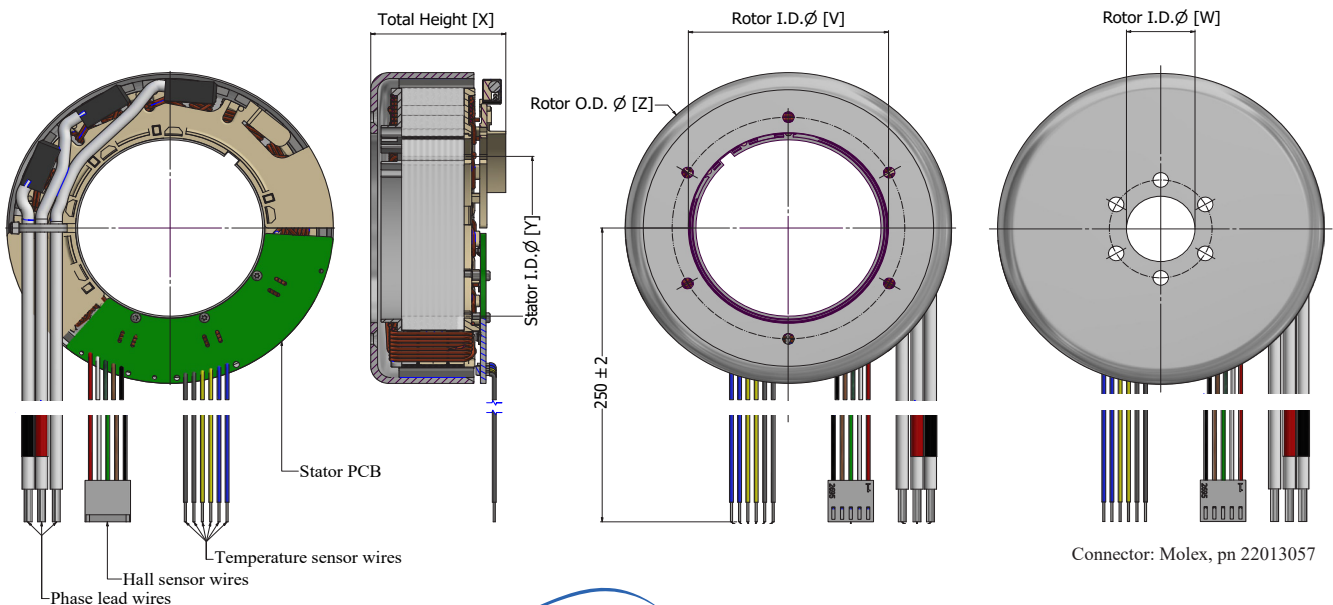

Sensors

Hall sensors

Hall sensor connections / specifications:

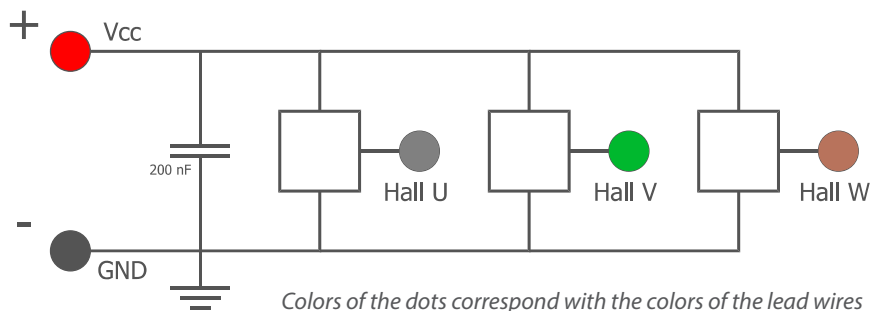

Specification Item	Value [Typ.]
Supply Voltage [VCC]	3.0 - 32 V
Supply Current	4.8 mA
Temperature Range	-40 °C + 170 °C
Output Type	Open drain
Max Output Voltage	32 V
Max Output Current	25 mA

Hall sensors switching sequence:

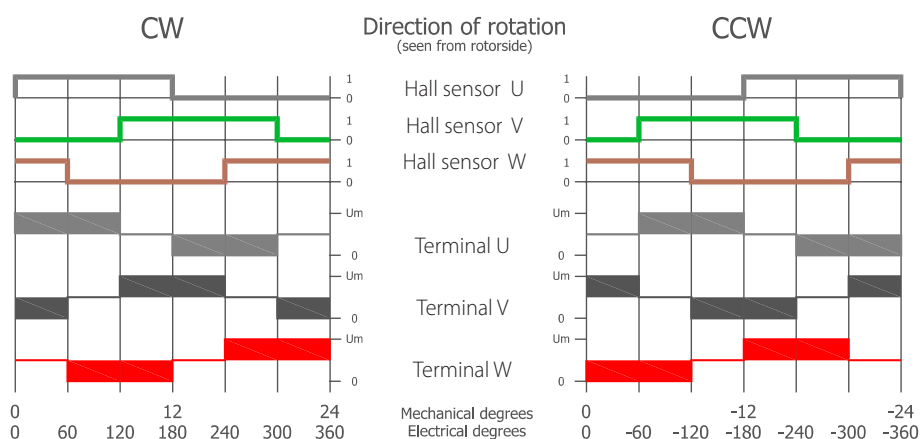

The colors of the 3 Hall sensor signals correspond with the 3 colors of the Hall lead wires.
The colors of the 3 signals of the terminals U, V, W, correspond with the 3 colors of the motor lead wires.

Temperature sensors

Temperature sensor connections / specifications:

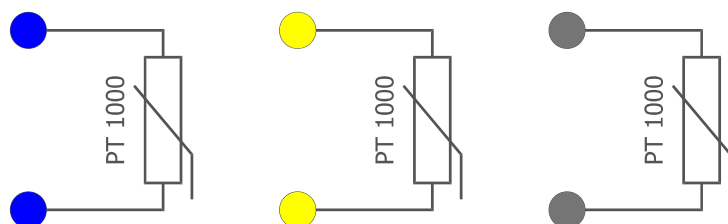

Specification Item	
Resistance at 0 °C	1000 Ohm
Temperature coefficient	+ 3850 ppm/K
Temperature Range	-40 °C to +175 °C
$\Delta T^{(1)}$	T.B.D.

Colors of the dots correspond with the colors of the lead wires, each wire color is used for a different motor phase.

(1) Due to the thermal coupling between the winding and sensor, the temperature measured by the sensor will be lower than the actual temperature of the winding.

Optional sensor types are possible after consulting the factory (PTC, NTC).

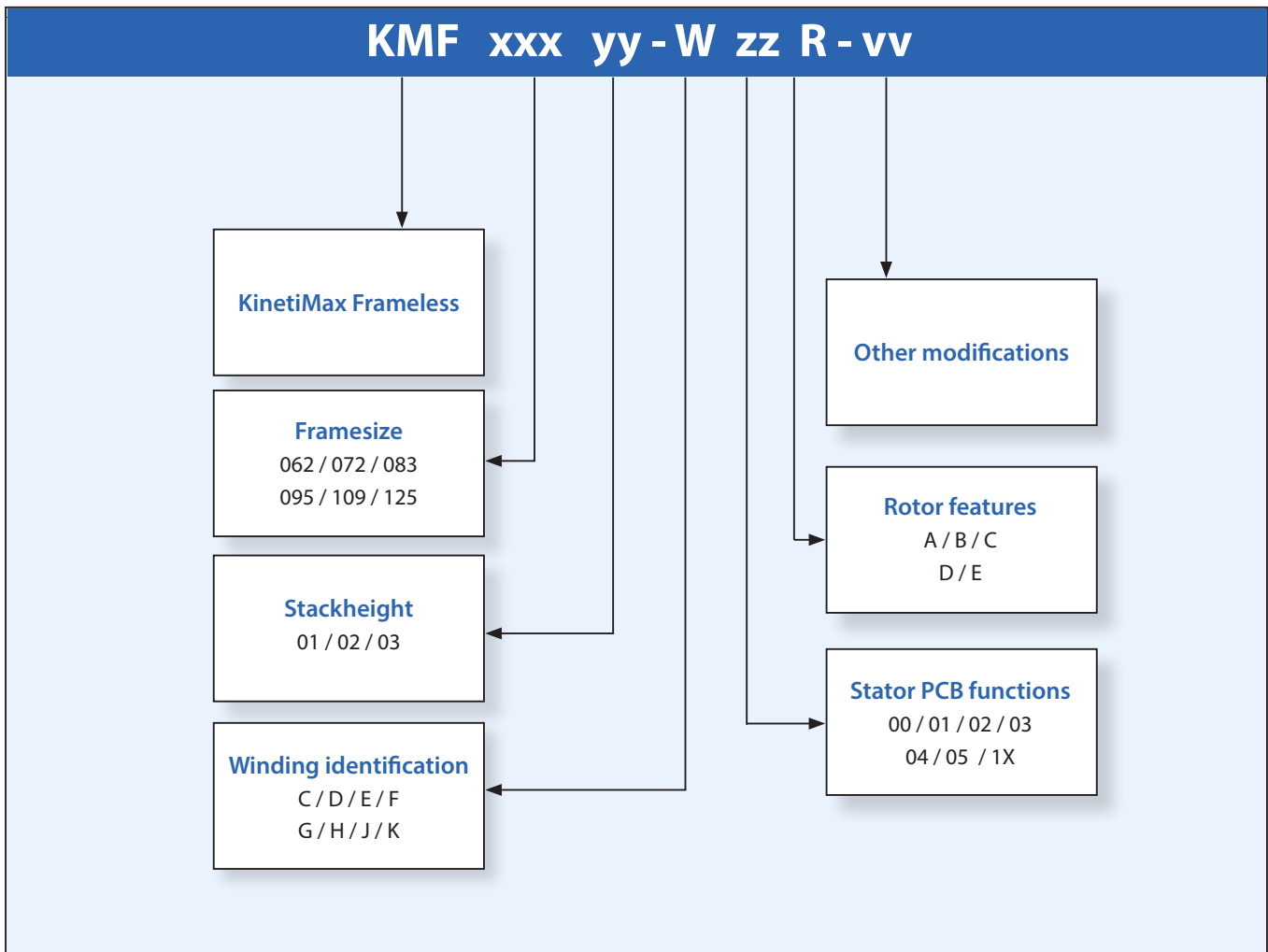

ZZ	Stator PCB functions
00	No PCB
01	PCB with 3 Hall sensors
02	PCB with 1 Temperature sensor only
03	PCB with 3 Hall sensors and 1 Temperature sensor
04	PCB with 3 Temperature sensors only
05	PCB with 3 Hall sensors and 3 temperature sensors
1X	Starting with 1 are custom PCB's

R	Rotor features
A	Large bore hole, G40 balancing class
B	Small bore hole, G40 balancing class
C	Large bore hole, G16 balancing class
D	Small bore hole, G16 balancing class
E	Custom rotor or balancing

With **Other modifications** are meant custom added parts to stator or rotor like a stator bracket, other leadwires with connector or a rotor nave/shaft etc.

Allied Motion Solution Centers

Allied Motion Solution Centers provide support to customers around the world from five geographically-strategic locations. Each facility is staffed by experienced application engineers and customer service teams to assist you with all aspects of your motion control needs. We also have a global network of factory-trained Allied Motion Sales Partners to serve you. For contact information on the location nearest you, please see below or visit our website.

Global Presence and International Support



North America (US, Canada, Mexico)

Amherst, New York (HQ)
+1 (716) 242-7535
inquiry@alliedmotion.com

Europe

Kelheim, Germany
+49 9441/707 - 0
inquiry.eu@alliedmotion.com

Asia

Changzhou, Jiangsu, China
+86-(0)519-8511 3625
inquiry@alliedmotion.com

Dordrecht, Netherlands
+31 (78) 621 9940
inquiry.nl@alliedmotion.com

Bromma, Sweden
+46 (8) 546 11 100
inquiry.eu@alliedmotion.com